



Delta BreezGreenBuilder

Perfectly quiet. Perfectly green.

Delta BreezGreenBuilder Series

VFB050C4L1	50 CFM Fan/Light Combo
VFB080C4L1	80 CFM Fan/Light Combo
VFB050C4A1	50 CFM Single Speed
VFB080C4A1	80 CFM Single Speed

Project Pack Components

VFB000C4L1F	Breez GreenBuilder Housing Can w/ Light
VFB050C4L1F	50 CFM Motor/Light Grille Assembly
VFB080C4L1F	80 CFM Motor/Light Grille Assembly
VFB000C4A1F	Breez GreenBuilder Housing Can w/o Light
VFB050C4A1F	50 CFM Motor/Grille Assembly
VFB080C4A1F	80 CFM Motor/Grille Assembly

The Builders choice for green construction.

The Delta BreezGreenBuilder Ventilation Fan marks a new achievement in ventilation for green construction. BreezGreenBuilder series fans feature a compact housing of 8.25" x 8.0" x 5.75" with or without a light option. Designed for easy retrofit into existing bathrooms and new construction.



Innovative DC brushless motor design for long life, low noise, and low power consumption.

- Energy savings up to 85%²
- Lowest sone level rated by HVI at <0.3 sones
- Exceeds Energy Star requirement by 935% in energy efficiency³

Project Pack Components Available



	Delta Breez	Market AC Motor
Energy Use (Watts)	4.0	27.1
Noise Level (Sones)	<0.3	1.5
Annual Energy Cost per Fan (24/7) ¹	\$4.20	\$28.48

¹ Calculations based upon U.S. average retail electricity and HVI testing labs. Actual results may vary.

² Based upon BreezGreenBuilder VFB050C4A1 vs. market AC motor fan.

³ Based upon Energy Star criteria for residential ventilating fans.



Specifications

Delta BreezGreenBuilder
Perfectly quiet. Perfectly green.

The Builders choice for green construction. Designed for easy retrofit and new construction.

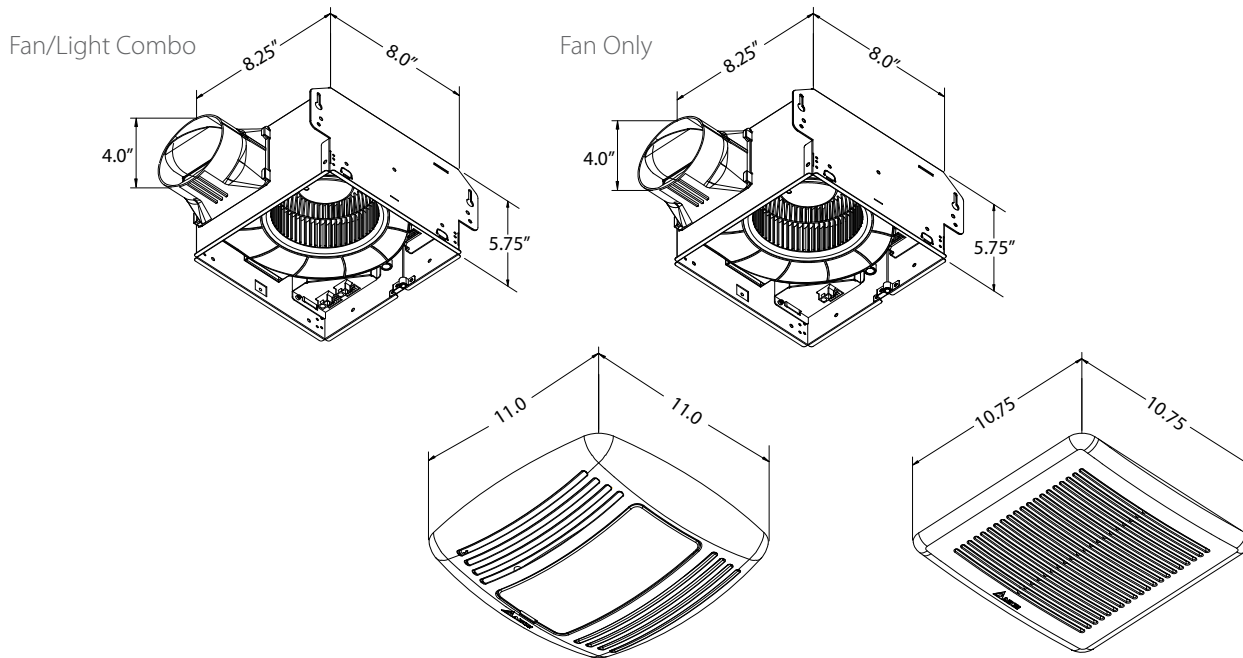

Delta BreezGreenBuilder Series	VFB050C4L1		VFB080C4L1		VFB050C4A1		VFB080C4A1	
Static Pressure (Inches w.g.)	0.1	0.25	0.1	0.25	0.1	0.25	0.1	0.25
Air Flow (CFM)	50	38	80	66	50	36	80	66
Sones	<0.3	0.7	0.8	1.0	<0.3	1.0	0.8	1.1
Power Consumption (Watts)	4.3	5.8	8.7	9.7	4.0	5.2	7.9	9.3
Energy Efficiency (CFM/Watt)	12.2	7.0	9.2	6.8	13.1	7.1	10.3	7.2
Current (Amps)	0.03@120Vac	0.05@120Vac	0.07@120Vac	0.07@120Vac	0.03@120Vac	0.04@120Vac	0.06@120Vac	0.07@120Vac
Power Rating (Volts/Hz)	120/60		120/60		120/60		120/60	
Duct Diameter (Inches)	4"				4"			
Mounting Opening (Inches)	8.25" x 8"				8.25" x 8"			
Mounting Depth (Inches)	5.75"				5.75"			
Grill Size (Inches Sq.)	11" x 11"				10.75" x 10.75"			
Lamp (Watts)	26				N/A			
Lamp Model #	GU24				N/A			
Shipping Gross Weight (lbs)	8.8				7.0			
cUL Tub/Shower Enclosure	Yes				Yes			
Washington State VIAQ Code	Yes				Yes			
California Title 24 Compliant	Yes				Yes			
Mfg in ISO 9001 Certified Factory	Yes				Yes			
Energy Star Certified	Yes				Yes			
Warranty (Years)	3				3			

