



	<p>4" Duct (Standard): 70 CFM/1.0 Sone @ 0.1 SP, 8.4 Watts 59 CFM/1.5 Sones @ 0.25 SP, 10.0 Watts</p>		
--	--	--	--

Description

Low noise ceiling mount ventilating Fan/LED Light rated for continuous running. Fan has been awarded ENERGY STAR® qualified. It is HVI, UL, and cUL certified, and can be used to comply with ASHRAE 62.2 (local and whole building continuous and intermittent operation), CA Title 24, and CALGreen requirements.

DC Motor/Blower

- Power rating of 120 volts/60Hz
- DC Brushless motor engineered to run continuously
- Motor equipped with thermal cutoff fuse
- Removable with permanently lubricated plug-in motor
- Built-in soft start function to increase bearings' life
- Automatically powers OFF when impeller is locked abnormally
- Self-compensating motor speed for intended airflow when static pressure is encountered

Housing

- Galvanized steel body
- Detachable 4" diameter plastic duct adapter
- Built-in backdraft damper
- Easy installation

Grille

- Attractive design using ABS material
- Attaches directly to housing with torsion springs

Light

- 13-Watt LED
- Light output 850 Lumens, 2700K
- Dimmable Lighting(dimmer switch not included)

Warranty

- 3-year limited warranty

TYPICAL SPECIFICATION

Ventilation fan shall be Delta Breez model ITG70LED; ENERGY STAR qualified with DC brushless motor engineered to run continuously for a minimum 70,000 hours; airflow rating of 70 CFM and loudness rating of 1.0 Sone at 0.1 static pressure as certified by the Home Ventilating Institute (HVI); power consumption of 8.4 Watts with efficiency rating of 8.3 CFM/Watt at 0.1" static pressure; motor lock protection and self-compensating motor speed for intended airflow when static pressure is encountered. UL and cUL listed for tub/shower enclosure when used with GFCI-protected branch circuit wiring.

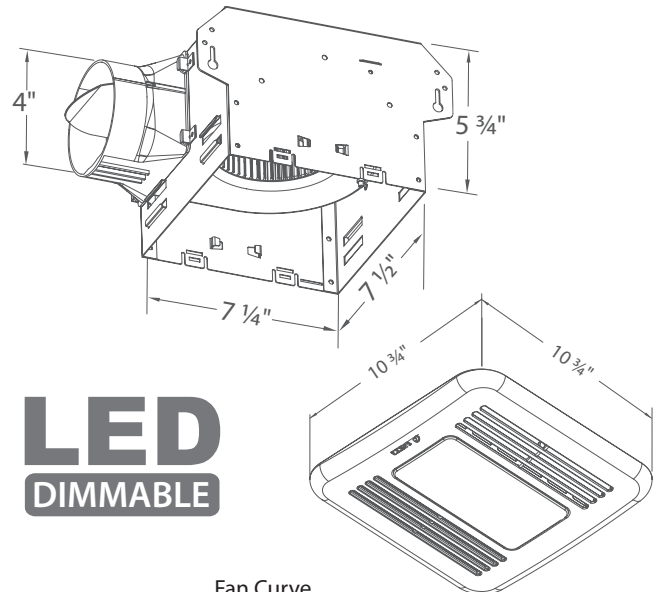

Fan Curve

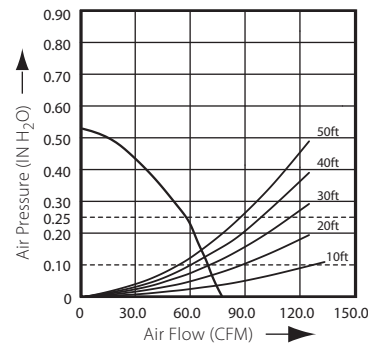

BreezIntegrity ITG70LED	4" Duct (Standard)	
Static Pressure (inches w.g.)	0.1	0.25
Air Flow (CFM)	70	59
Sones	1.0	1.5
Power Consumption (Watts)	8.4	10.0
Energy Efficiency (CFM/Watt)	8.3	5.9
Current (Amps)	0.25 Max	
Power Rating (V/Hz)	120/60	
LED Light (Watt)	13.0	

Model	Quantity	Comments	Project:
			Location:
			Architect:
			Engineer:
			Contractor:
			Submitted by:
			Date: