

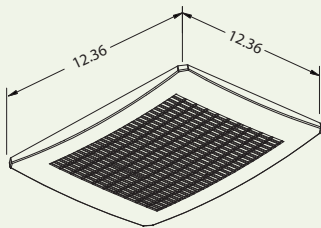

Delta BreezSignature Ventilation Humidity Sensor Fan Specifications

VFB25AEH
(130 CFM)

Dimensions

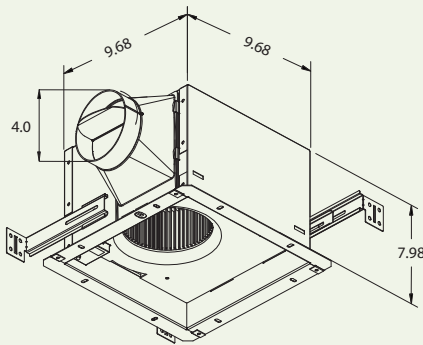

UNIT: INCH

Fan Curve

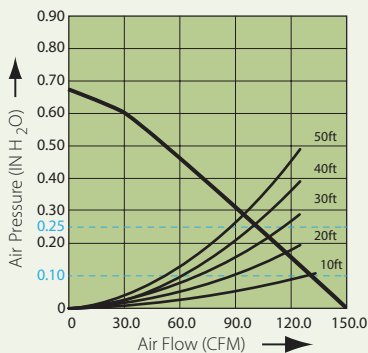

Humidity Control

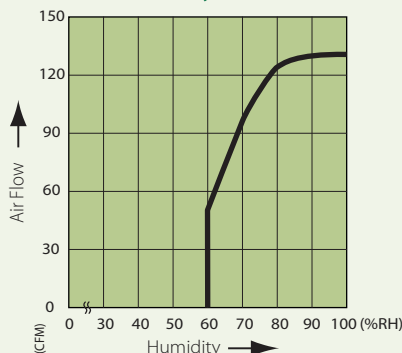

VFB25AEH-10/11

Description

Low noise ceiling mount ventilating fan with humidity sensor, rated for continuous running. Evaluated by Underwriter Laboratories and conforms to both UL and cUL safety standards.

Motor/Blower

- Power Rating of 110~220volts/50~60Hz.
- DC Brushless motor engineered to run continuously.
- Motor equipped with thermal cutoff fuse.
- Permanently lubricated motor.

Housing

- Galvanized steel body.
- Detachable 4" diameter duct adapter.
- Built in backdraft damper.
- Easy installation.

Grille

- Attractive design using ABS material.
- Attaches directly to housing with torsion springs.

Warranty

- 3 year limited warranty.

Features

- Blue and amber LED indicator lights to show humidity sensor and full speed modes.
- For ceiling mount only, air flow of 130 CFM ($\pm 10\%$) and approximately 1.3 Sones at 0.1" static pressure.
- Power consumption not to exceed 19.1 Watts with an efficiency rating no less than 7.1 CFM/Watt at 0.1" static pressure.
- Duct diameter no less than 4".
- UL and cUL listed for tub/shower enclosure when used with GFCI branch circuit wiring.

DC Motor Technology

- Allows fan to operate in full speed mode or humidity control mode by cycling ON/OFF switch.
- Built in soft start function to increase bearings life.
- Automatically powers OFF when impeller is locked abnormally.

Specifications

VFB25AEH	4" Duct (Standard)	
Static Pressure (Inches w.g.)	0.1	0.25
Air Flow (CFM)	130	107
Sones	1.3	N/A
Power Consumption (Watts)	19.1	18.8
Energy Efficiency (CFM/Watt)	7.1	5.9
Speed (RPM)	1083	1219
Current (Amps)	0.36 @ 110 Vac	
Power Rating (V/Hz)	110~220/50~60	