

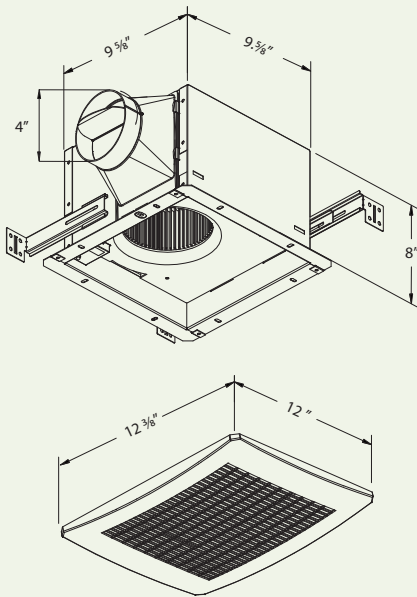

Delta BreezSignature Ventilation Humidity Sensor Fan Specifications

VFB25ADH
(110 CFM)

Dimensions



Fan Curve

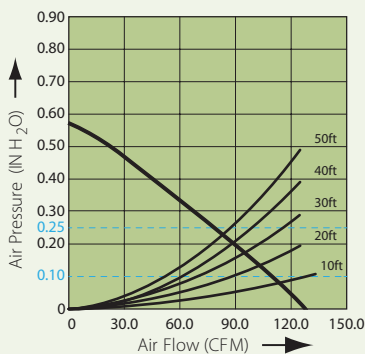

Humidity Control

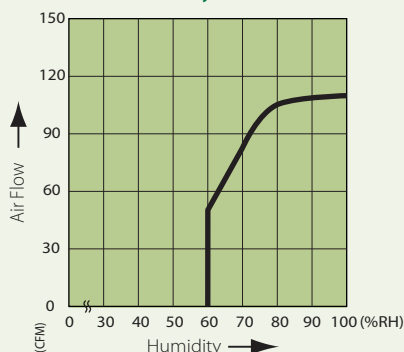

Description

Low noise ceiling mount ventilating fan with humidity sensor, rated for continuous running. ENERGY STAR qualified. Evaluated by Underwriter Laboratories and conforms to both UL and cUL safety standards.

Motor/Blower

- Power rating of 110~220volts/50~60Hz
- DC brushless motor engineered to run continuously
- Motor equipped with thermal cutoff fuse
- Permanently lubricated motor
- Meets or exceeds the requirements set forth by ASHRAE 62.2 for continuous or intermittent running applications

Housing

- Galvanized steel body
- Detachable 4" diameter duct adapter
- Built-in backdraft damper
- Easy installation

Grille

- Attractive design using ABS material
- Attaches directly to housing with torsion springs

Warranty

- 3-year limited warranty

Features

- Blue and amber LED indicator lights to show humidity sensor and full speed modes
- For ceiling mount only, air flow of 110 CFM ($\pm 10\%$) and approximately 1.0 Sone at 0.1" static pressure
- Power consumption approximately 14.2 Watts with an efficiency rating approximately 7.7 CFM/Watt at 0.1" static pressure
- Duct diameter no less than 4"
- UL and cUL listed for tub/shower enclosure when used with GFCI branch circuit wiring

DC Motor Technology

- Allows fan to operate in full speed mode or humidity control mode by cycling ON/OFF switch
- Built-in soft start function to increase bearings' life
- Automatically powers OFF when impeller is locked abnormally

Specifications

VFB25ADH	4" Duct (Standard)	
Static Pressure (Inches w.g.)	0.1	0.25
Air Flow (CFM)	110	81
Sones	1.0	1.5
Power Consumption (Watts)	14.2	15.0
Energy Efficiency (CFM/Watt)	7.7	5.3
Current (Amps)	0.22 @ 110 Vac	
Power Rating (V/Hz)	110~220/50~60	