

Fig. 1

SMT-CRD2 Combustible Ceiling Installation Instructions

For fan models: SMT130, SMT130M, SMT130H, SMT150, SMT150D, SMT150LED, SMT150-200, SMT150-200LED, SLM80, SLM100, SLM80-110-C, SLM80-110LED-C, SLM80-110D-C, SLM80-110DLED-C, SLM80-110H-C, SLM50-110-C, SLM50-110LED-C

1. Install the radiation damper onto the inlet side of the fan so that the holes in the sleeve align with the mounting holes on the fan using the four #10-32 x 1/4" long screws provided with the damper assembly. (Refer Fig. 1)
2. Prior to the gypsum ceiling being placed, install the Damper Supports 11-3/4" on center at the location of the damper and fan assembly. The supports consist of four pieces of 2x4's cut to the truss/joist height. The supports are to be flush mounted to the bottom of the joist/truss and secured using at minimum 2" wood screws. (Refer Fig. 1)
3. When using a fan equipped with a grille light, rotate the wire door and bend down the slot cover with a screwdriver. Route the wire from the grille through the slot, and rotate the wire door back to its original position to secure the wire. (Refer Fig. 2)

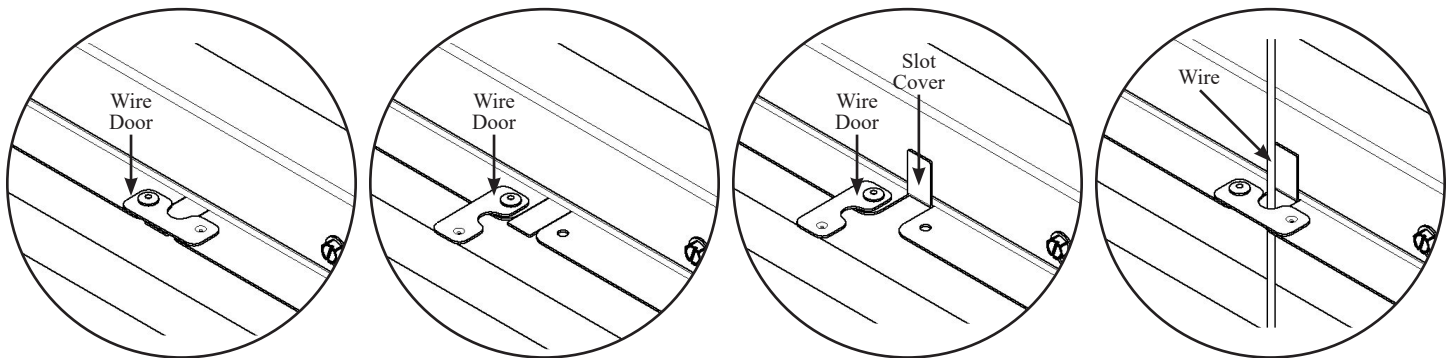

Fig. 2 - Fan with Light

4. Install the fan Suspension Brackets on the fan/damper assembly.

5. Scribe a line on each of the damper supports, measured from the bottom of the truss and using the below equation:
 $\text{Mounting Distance} = 2 \frac{1}{2} - \text{Resilient Channel Height}$ (Refer Fig. 3)

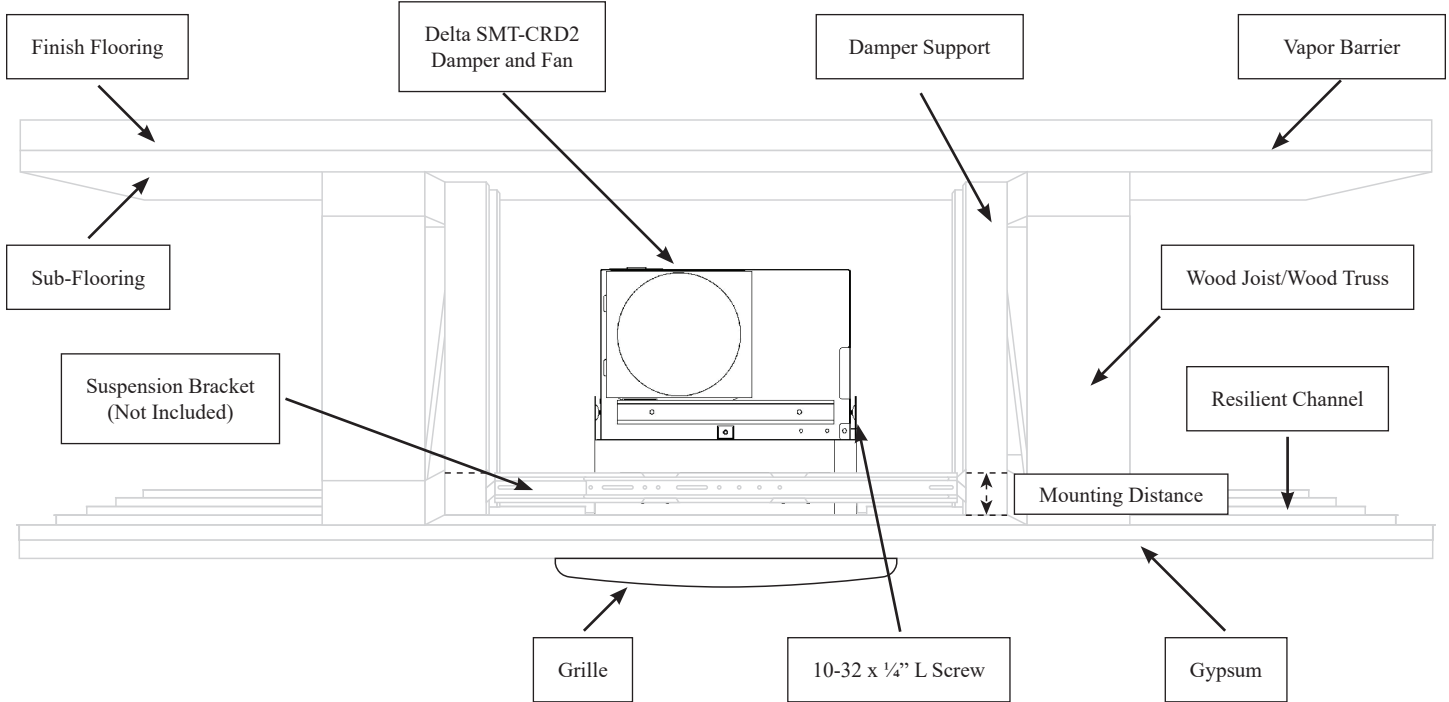
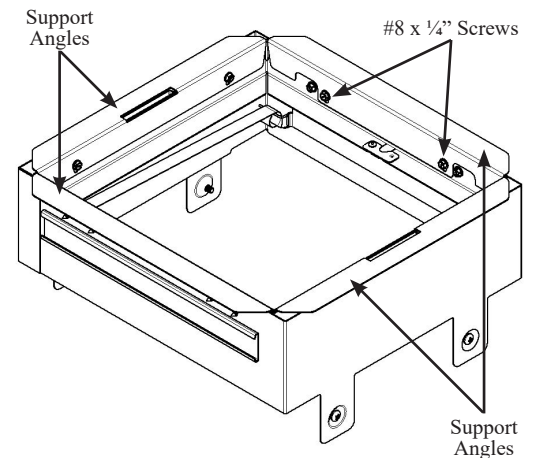

Fig. 3

6. Position the fan/damper assembly in the ceiling construction so that the tops of the fan Suspension Brackets are flush with the scribed line. Drive in the 6D nails at the ends of the fan Suspension Brackets into the 2x4's to secure the assembly in the ceiling.
7. After the gypsum ceiling has been installed, secure the supplied support angles to the damper frame with the supplied #8 screws using the pre-drilled holes in the frame. (Refer Fig. 4)
8. Insert the grille springs into the grille brackets on the frame and push up against the ceiling.

Installation is valid for the following UL rated wood truss ceilings:

- Floor-Ceiling = L587 (Owned) Also found in the following floor-ceiling designs: L528, L558, L562, L563 L574, and L585
- Roof Ceiling = P556 (Owned) Also found in the following roof-ceiling designs: P533, P544, P545, P547, and P580



**Fig. 4 - Support Angles
Installation**

