

CEILING/WALL VENTILATION FAN

Installation and Operating Instructions

MODELS: ELT50-110 / ELT50-110D / ELT50-110H / ELT50-110MH
 ELT50-110LED / ELT50-110DLED / ELT50-110HLED / ELT50-110MHLED

READ AND SAVE THESE INSTRUCTIONS

GENERAL SAFETY INFORMATION

1. Make sure that the electric service supply voltage is AC 120V, 60Hz.
2. Follow all local electrical and safety codes, as well as the National Electrical Code (NEC) and the Occupational Safety and Health Act (OSH Act).
3. Always disconnect the power source before working on or near the ventilating fan, motor or junction box.
4. Protect the power cord from sharp edges, oil, grease, hot surfaces, chemicals or other objects.
5. Do not kink the power cord.
6. Do not install the unit where ducts are configured as shown in Fig.A.
7. Provide suction parts with proper ventilation.
8. This unit is UL Listed for use over a bathtub or shower when installed in a GFCI protected branch circuit.

2. Not for use in cooking areas. (Fig.B)
3. This product must properly connect to the grounding conductor of the supply circuit.
4. To reduce the risk of injury to persons, install the fan at least 8.2 feet (2.5m) above the floor.

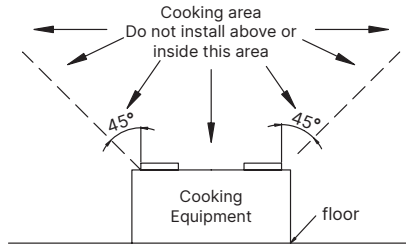

Fig. B

WARNING

TO REDUCE THE RISK OF FIRE, ELECTRIC SHOCK, OR INJURY TO PERSONS, OBSERVE THE FOLLOWING:

1. Use this unit only in the manner intended by the manufacturer. If you have questions, contact the manufacturer.
2. Before servicing or cleaning the unit, switch the power off at the service panel and lock the service disconnecting means to prevent the power from being switched on accidentally. When the service disconnecting means cannot be locked, securely fasten a prominent warning device, such as a tag, to the service panel.
3. Installation work and electrical wiring must be done by a qualified person(s) in accordance with all applicable codes and standards, including fire-rated construction.
4. Sufficient air is needed for proper combustion and exhausting of gases through the flue (chimney) of fuel burning equipment to prevent backdrafting. Follow the heating equipment manufacturer's guideline and safety standards such as those published by the National Fire Protection Association (NFPA), and the American Society for Heating Refrigeration and Air Conditioning Engineers (ASHRAE) and local code authorities.
5. When cutting or drilling into the wall or ceiling, do not damage electrical wiring and other hidden utilities.
6. Ducted ventilating fans must always be vented to the outdoors.
7. If this unit is to be installed over a tub or shower, it must be marked as appropriate for the application and be connected to a GFCI (Ground Fault Circuit Interrupter) – protected branch circuit.
8. Do not use this unit with any other solid-state control device. Solid-state controls may cause harmonic distortion, which can cause a motor humming noise.
9. NEVER place a switch where it can be reached from a tub or shower.
10. Not to be installed in a ceiling thermally insulated to a value greater than R50. (This is required for installation in Canada only).
11. Do not open/disassemble LED light engine.

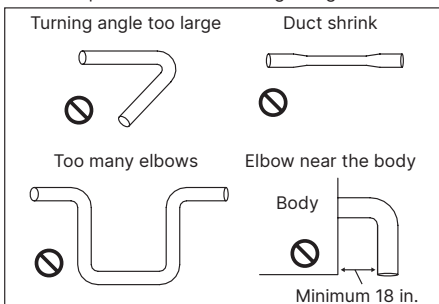

Fig. A

PREPARATION

Tools Required for Assembly (not included): Hammer, Flathead Screwdriver, Wire Nuts, Nails, Duct Tape, Phillips Head Screwdriver, Utility Knife
 Helpful Tools (not included): Electric Drill, Drill Bits.

WARNING: Turn off electricity at breaker box before beginning installation.

- Carefully remove unit from carton.
- Check area above installation location to be sure that wiring can run to the planned location and that duct work can be run. Make sure the area is sufficient for proper ventilation.
- Inspect duct work and wiring before proceeding with installation.
- Before installation, provide inspection and future maintenance access at a location that will not interfere with installation work.
- You may need the help of a second person to install this fan: one person on the attic side and one on the room side.

Note: Installations may vary depending on how the previous bath fan was installed. Supplies necessary for the installation of your bath fan are not all included. However, most are available at your local home improvement or hardware store.

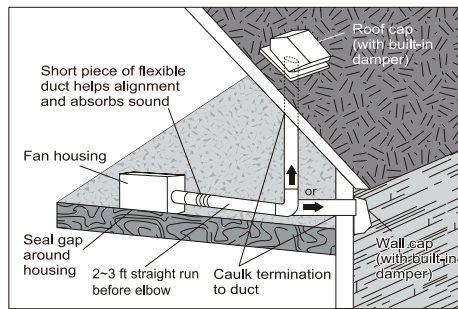

Proper insulation around the fan to minimize building heat loss and gain. The ducting from this fan to the outside of building has a strong effect on air flow, noise and energy use of the fan. Use the shortest, straightest duct routing possible for best performance, and avoid installing the fan with smaller ducts than recommended. Insulation around the ducts can reduce energy loss and inhibit mold growth. Fans installed with existing ducts may not achieve their rated air flow.

- The fan will operate most efficiently when located where the shortest possible duct run and minimum number of elbows will be needed.
- Use a roof cap or wall cap that has a built-in damper to reduce backdrafts.
- External timer can be used in conjunction with single-speed mode only, please contact Delta Breez customer service and consult with a licensed electrician for compatibility.
- External dimmer can be used in conjunction with LED light model, please contact Delta Breez customer service and consult with a licensed electrician for compatibility.

For humidity sensing models only (ELT50-110H / ELT50-110MH / ELT50-110HLED / ELT50-110MHLED)

- Locate unit above (GFCI-protected circuit required) or within 5 feet of the shower head.
- Locate unit away from heating or cooling sources which can affect humidity levels.
- Do not locate near window. Unit may respond to the outdoor humidity level.
- Unit must be installed in ceiling to properly sense moisture.
- Locate unit only on flat ceilings up to 12 feet high for proper sensing.

PACKAGE CONTENTS

For all Models:

Part name	Appearance	Qty
Fan Body		1
Duct		1
Tapping Screw (ø4×25mm)		8
Machine Screw (#8-32×5/16")		4
Hanger Bar		4

For the Model of ELT50-110 / ELT50-110H

Part name	Appearance	Qty
Grille		1

For the Model of ELT50-110LED / ELT50-110HLED

Part name	Appearance	Qty
Grille		1

For the Model of ELT50-110MH

Part name	Appearance	Qty
Grille		1

For the Model of ELT50-110MHLED

Part name	Appearance	Qty
Grille		1

CAUTION

1. For General Ventilating Use Only. Do Not Use To Exhaust Hazardous Or Explosive Materials And Vapors.



501627830002

ASSEMBLY INSTRUCTIONS BEFORE INSTALLATION

Turn off power source. Review all safety precautions.

NEW CONSTRUCTION USING HANGER BARS

1. Assemble the duct from top to bottom of housing into position.

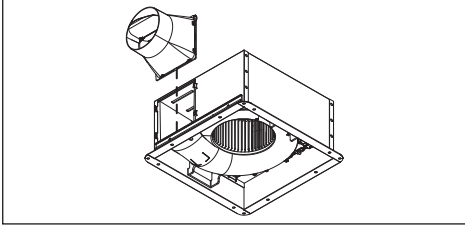

2. Insert hanger bars into the channels on housing. Sliding hanger bars to allow for your specific positioning of housing anywhere between joists and span up to 24 in.

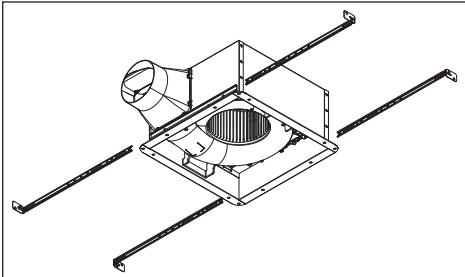

3. Extend hanger bars to the width of the joists. Make sure the fan body is level and perpendicular with the joist, and flush with ceiling surface. Fasten hanger bars to joists with tapping screws (ø4×25 mm) or nails (not provided). Secure hanger bars together with machine screws (# 8-32×5/16").

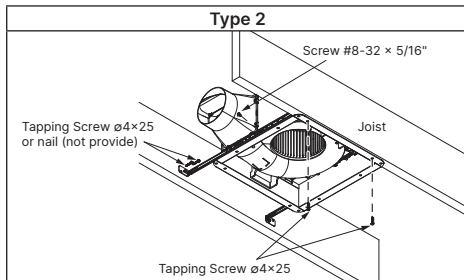
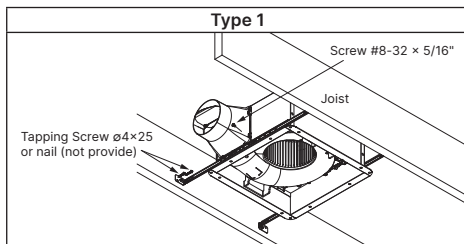

EXISTING CONSTRUCTION - ACCESSIBLE FROM BELOW (No Attic Access)

1. Remove existing fan. Measure the ceiling or wall opening and cut a new opening to ensure it is large enough to accommodate the new fan (10 1/2 in. × 10 1/2 in. suggested).

A piece of wood (not provided) may be necessary that is screwed in from below through the ceiling board.

Suggested size is H 4 in. × L 16 in. Position the screws far enough from the edge of the ceiling board that it does not crumble and give way.

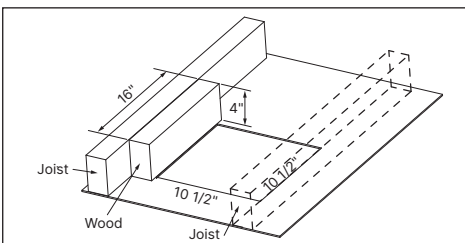

2. Unplug all connectors from wiring panel. Remove the fan body by release three machine screws (M4×45 mm).

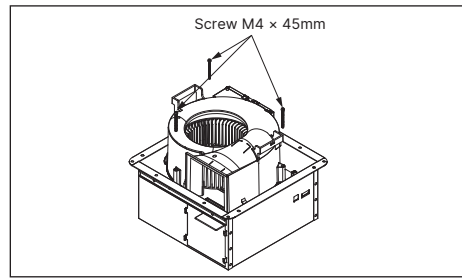

3. Using wire nuts (not provided) connect house wires to fan wires as shown in connect wiring diagram A.

4. Insert housing into ceiling opening and secure housing to the wood or the ceiling by using tapping screws (ø4×25 mm).

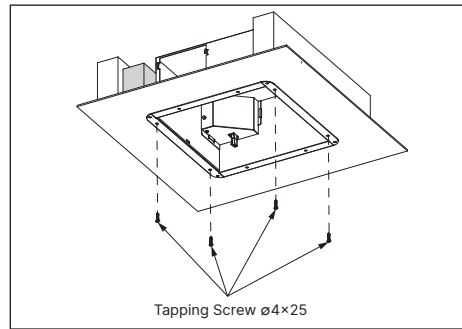

5. Do the duct work as below picture and follow "DUCT CONNECTION" and insert the duct connector into the opening inside the housing, and snap it into place using the locking tabs on the duct connector.

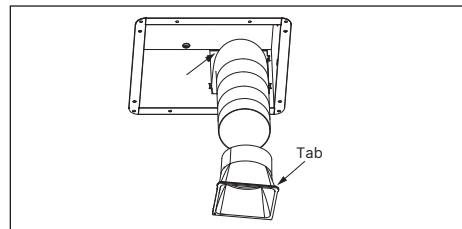

6. Then insert fan body into housing by using three machine screws (M4×45 mm) originally on the fan body and plug in all connectors.

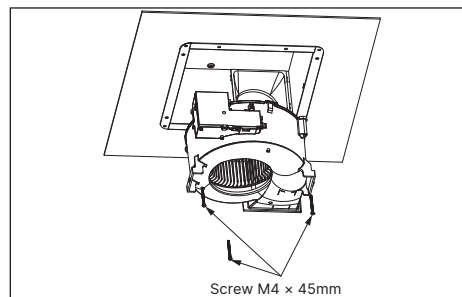

DUCT CONNECTION

Connection method for 4" oval duct connector

1. Insert the duct into the duct connector and tape all ductworks connection to make them secure and air tight.
2. Install the duct with a gradient 1°~2° to the outside.

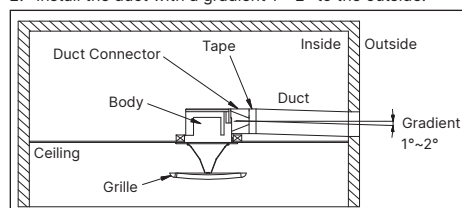

CONNECT WIRING

TURN OFF POWER SOURCE.
REVIEW ALL SAFETY PRECAUTION.

1. Follow all local electrical and safety codes, ANSI/NFPA70.
2. NEVER place a switch where it can be reached from a tub or shower.
3. Use wire nuts (not provided) and connect house power cable to ventilating fan as below diagram.
4. 14 AWG (2.1 mm²) is the smallest conductor that shall be used for branch-circuit wiring.
5. Remove wiring cover from housing. Choose a hole and use a slotted screwdriver to remove a hole on wiring cover.
6. Push all wires into wiring compartment of units, use screw to secure wiring cover to housing.

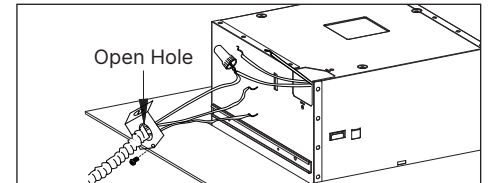

CONVENTIONAL WIRING DIAGRAM

1. ELT50-110 / ELT50-110MH

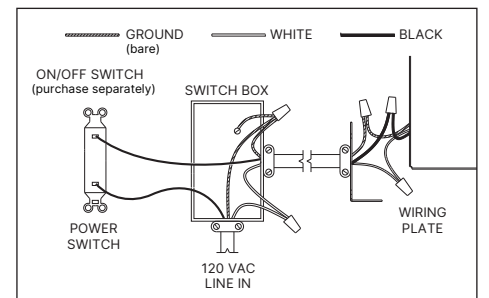
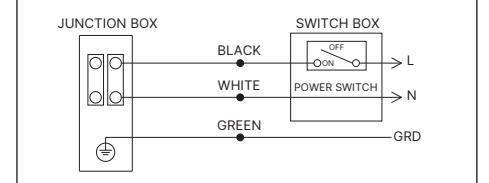

2. ELT50-110D / ELT50-110H

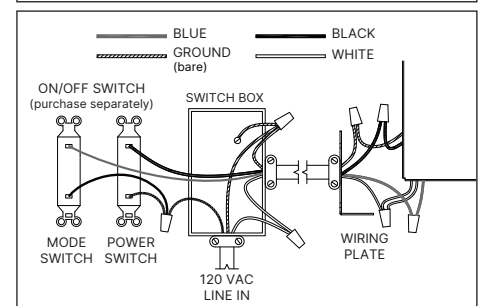
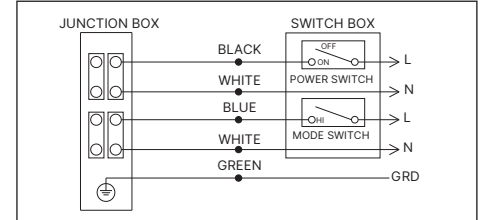

3. ELT50-110ED / ELT50-110MHED

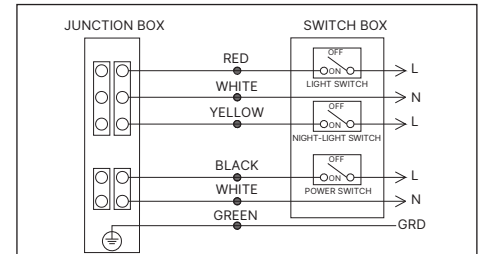

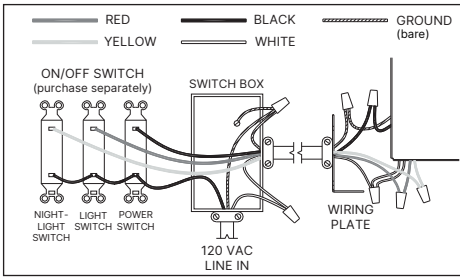

4. ELT50-110DLED / ELT50-110HLED

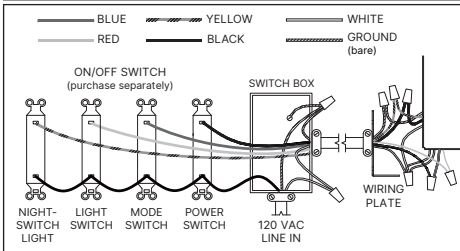
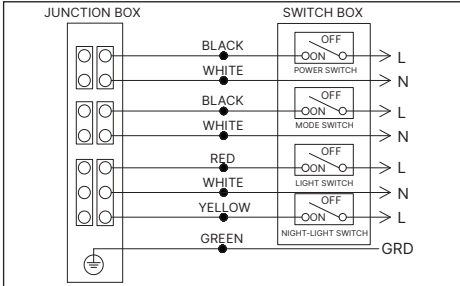

OTHER WIRING OPTION

See OPERATION section for detail description of "mode".

5. ELT50-110D / ELT50-110H

Hardwire power

- Switch OFF: Fan runs 24 hours at "Low speed control mode": (ELT50-110D only)
- Switch OFF: Fan runs 24 hours at "Humidity control mode": (ELT50-110H only)
- Switch ON: Fan runs at user adjustable full speed airflow.

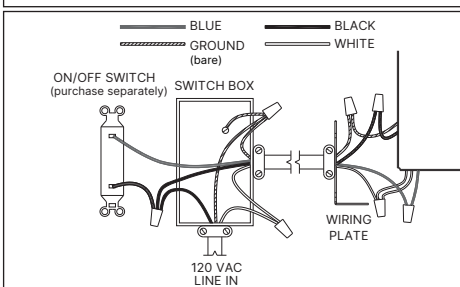
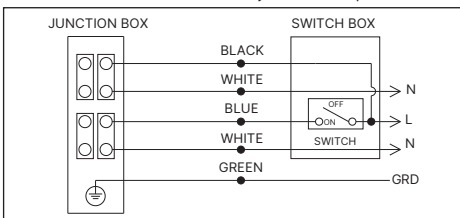

6. ELT50-110LED / ELT50-110MHLED

Combine power & light to one switch.

- Switch ON for ELT50-110LED: Fan runs at user adjustable full speed airflow and the light on at the same time.
- Switch ON for ELT50-110MHLED: Fan runs at "Motion control mode" and the light on at the same time.

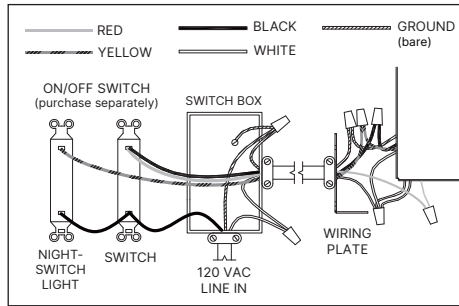
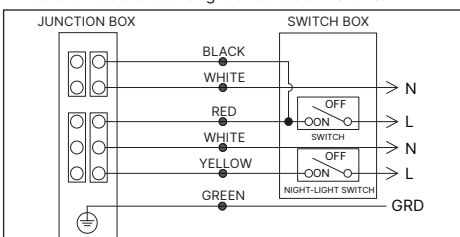

7. ELT50-110DLED / ELT50-110HLED

Hardwire power and combine mode & light to one switch.

- Switch OFF: Fan runs 24 hours at "Low speed control mode": (ELT50-110DLED only)
- Switch OFF: Fan runs 24 hours at "Humidity control mode": (ELT50-110HLED only)
- Switch ON: Fan runs "Full speed mode" and light on at the same time.

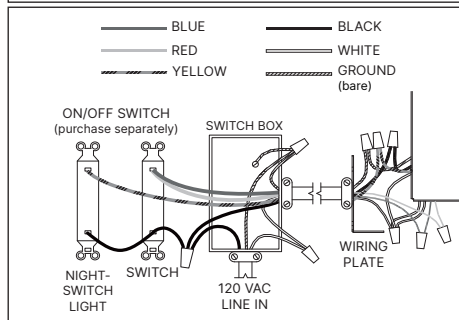
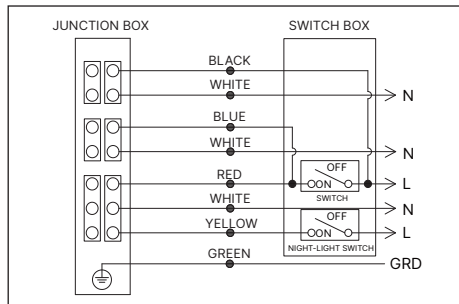

GRILLE INSTALLATION

1. LED Models :

Insert the LED lighting connector into the power socket of main body.

Using the switch on the back of grille, choose the color temperature you want for your LED. You can choose from 2700K warm white, 3000K soft white, 3500K neutral white, 4000K cool white, and 5000K daylight white.

2. ELT50-110MH / ELT50-110MHLED :

Insert the motion plug connector into the fan body.

3. All Models :

Insert the mounting springs into the slots and mount the grille to the fan body.

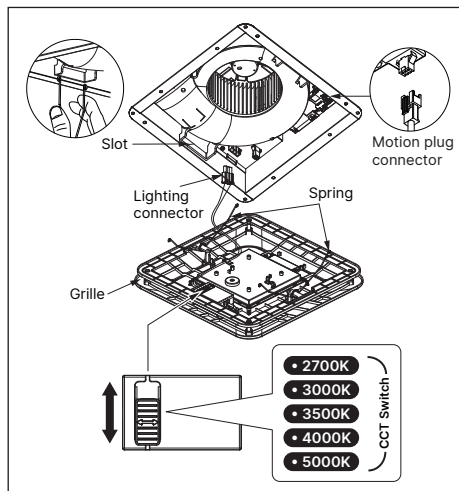

OPERATION

Single Speed Models: ELT50-110 / ELT50-110LED

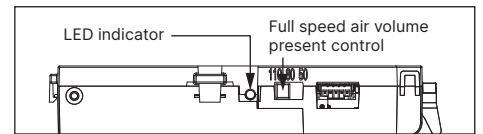

1. Turn the POWER switch on to operate at user adjustable full speed airflow - the LED indicator will be green.

Dual Speed Model: ELT50-110D / ELT50-110DLED

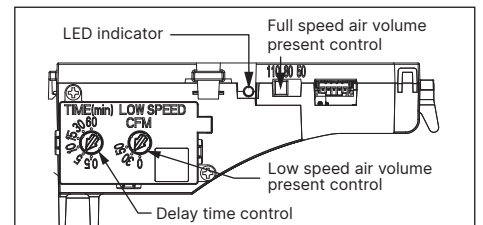

1. Low speed control mode: Turn the POWER switch on (MODE switch is off) to operate at the user-adjustable low speed airflow - the LED will be green
 2. Full speed control mode: Turn the POWER switch & MODE switch on to operate at user-adjustable full speed mode - the LED indicator will be amber. When the user turns the MODE switch off, the fan will continue to run at the full speed until the user-adjustable time delay has elapsed, and then will automatically change to the user-adjustable low speed airflow. The LED indicator will be green.
- Factory setting: High speed airflow 110 CFM, low speed airflow 30 CFM, time delay 5 minutes.

Humidity Models: ELT50-110H / ELT50-110HLED

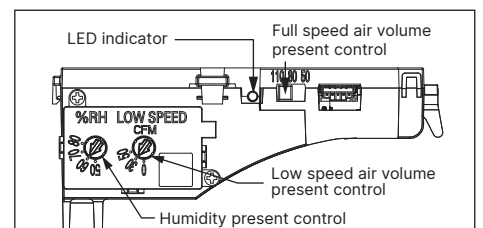

1. Humidity control mode: Turn the POWER switch on to operate at humidity control mode - the LED indicator will be blue. When the ambient humidity is higher than the user-adjustable set-point, the fan will run at full speed, and the LED indicator is blue. When the ambient humidity is lower than the set-point, the fan will continue to run at the full speed until a 10-minute time delay has elapsed, and then will automatically change to the user-adjustable low speed airflow.
 2. Full speed mode: Turn the MODE switch on to operate at user-adjustable full speed airflow - the LED indicator will be amber.
 3. Humidity tolerance is about ±10%. The humidity switch may need to be adjusted regionally. Longtime operation will influence the detecting precision as dust accumulates.
- Factory setting: High speed airflow 110 CFM, low speed airflow 30 CFM, humidity 60% RH.

Motion / Humidity Models:

ELT50-110MH / ELT50-110MHLED

1. Motion control mode: Turn the POWER switch on to operate at motion control mode. When motion is detected, the fan will run at user-adjustable full speed airflow and the LED indicator will be amber. When motion is not detected, the fan will continue to run at the full speed until a 10-minute time delay has elapsed, and then will automatically change to the humidity control mode. The LED indicator will be blue.

- Factory setting: High speed airflow 110 CFM, low speed airflow 0 CFM, humidity 80%RH.

Motion sensor detectable range: The distance that motion can be detected is limited to 10 feet (3m). The field of view of the sensor is 90° (Room temperature is 77°F / 25°C).

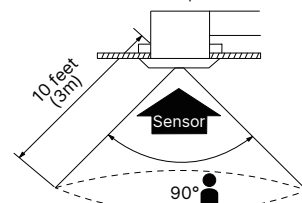

DIMENSIONS Unit: Inch

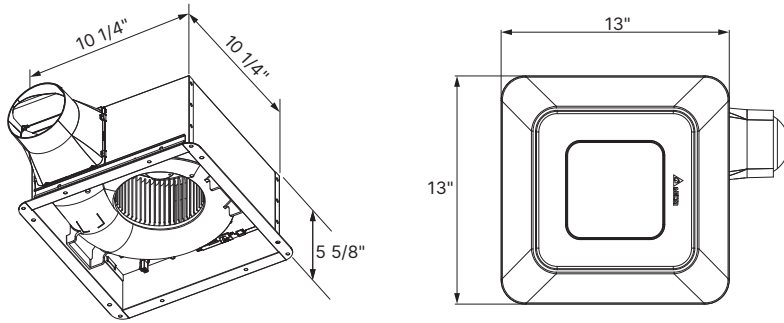

PRODUCT SPECIFICATIONS

Model No.	Voltage (V)	Frequency (Hz)	Air Flow @ 0.1SP (CFM)	Power @ 0.1SP (W)	Max Current (amps)	Weight (lb.)	Note	Light Spec
ELT50-110	120	60	110	13	0.45	6.8	Single Speed	13 Watt, 1000 Lumens, selectable color temperatures of 2700K, 3000K, 3500K, 4000K, and 5000K, CRI90
ELT50-110D	120	60	110	13	0.45	6.8	Dual Speed	
ELT50-110H	120	60	110	13	0.45	6.8	Humidity Sensing	
ELT50-110MH	120	60	110	13	0.45	6.8	Humidity & Motion Sensing	
ELT50-110LED	120	60	110	13	0.57	7.3	Single Speed	
ELT50-110DLED	120	60	110	13	0.57	7.3	Dual Speed	
ELT50-110HLED	120	60	110	13	0.57	7.3	Humidity Sensing	
ELT50-110MHLED	120	60	110	13	0.57	7.3	Humidity & Motion Sensing	

Note: Design and specifications subject to change without notice.

TROUBLESHOOTING

PROBLEM	POSSIBLE CAUSE	CORRECTIVE ACTION
The fan is not turning ON	<ol style="list-style-type: none"> Power off Faulty switch Faulty wire connection 	<ol style="list-style-type: none"> Make sure power supply is on. Test or replace switch. Check wire in switch box.
The fan seems louder than it should	<ol style="list-style-type: none"> CFM too great Damper not working properly or damaged Bend in duct too close to fan discharge Fan discharge reduced to fit smaller duct Fan body not securely attached 	<ol style="list-style-type: none"> Be sure the CFM rating on the fan matches the size of your room. Check damper to ensure it is opening and closing properly. If the damper has become damaged, please call Customer Service. Be sure you do not have any sharp bends in duct closer than 18 in. to the fan discharge. Use recommended size ducting to reduce fan noise. Be sure the fan is securely attached to your ceiling joists.
The fan is not clearing the room	<ol style="list-style-type: none"> Insufficient intake airflow within room Insufficient CFM 	<ol style="list-style-type: none"> Be sure a door or window is slightly ajar or opened to allow airflow. The fan is not able to draw air out of the room without enough airflow to draw in from. Be sure the CFM rating on the fan matches the requirements for your room size.
The light is not turning ON	<ol style="list-style-type: none"> Power off Faulty switch Faulty wire connection 	<ol style="list-style-type: none"> Make sure power supply is on. Test or replace switch. Check wire in switch box.
The fan keeps running even though the house humidity level is lower than user-adjustable set-point.	<ol style="list-style-type: none"> Our sensor tolerance is +/- 10% RH Outdoor humidity is back drafting to the fan 	<ol style="list-style-type: none"> Continue to let the fan run since it is good to keep venting the house and the electric bill is minimal (approximately less than \$10 per year). Turn the fan off when not in use.

CARE AND MAINTENANCE

TURN OFF POWER SOURCE. REVIEW ALL SAFETY PRECAUTION.

See safety information before proceeding. Routine maintenance should be done at least once a year.

- Never use solvents, thinner or harsh chemicals when cleaning the fan.
 - Do not allow water to enter the motor.
 - Do not immerse metal parts in water.
 - Do not immerse resin parts in water over 140°F.
1. To remove grille, squeeze springs and pull down. Wash and clean grille with non-abrasive kitchen detergent. Then wipe dry with a new cloth.
 2. Remove dust and dirt from the fan body with a vacuum cleaner.
 3. Using a cloth dampened with non-abrasive kitchen detergent, remove dust and dirt from the fan body. Then wipe dry with new cloth.
 4. Replace the grille back onto the fan body. Turn on fan switch to operate fan again.

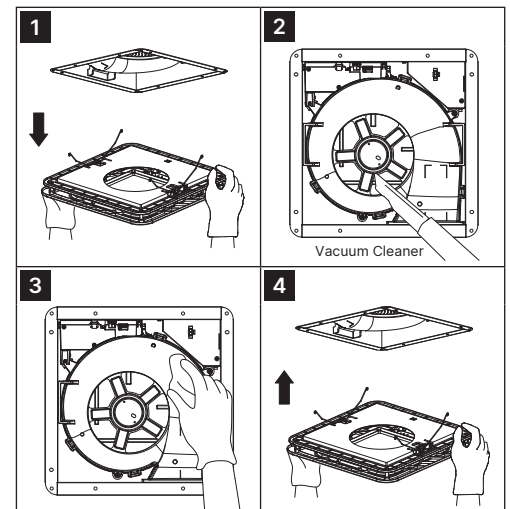

Address: 46101 Fremont Boulevard, Fremont, CA 94538
 US Toll Free Number:
 1-888-979-9889 – Technical Support
 1-877-685-4384 – Customer Sales Support
 www.deltabreez.com

WARRANTY

DELTA ELECTRONICS THREE YEAR LIMITED WARRANTY
 Delta Electronics Inc. ("Delta Electronics") warrants to the original consumer purchaser in the USA that the Breez ventilation fan products will be free from defects in material or workmanship. This warranty is limited to three (3) years from the original date of purchase.

Limitations and Exclusions

1. During the warranty period, a replacement for any defective product will be supplied free of charge for installation by the consumer. The warranty provided herein does not cover charges for labor or other costs incurred in the troubleshooting, repair, removal, and installation service.
2. All returns of defective parts or products must include the product model number, and must be made through an authorized Delta Electronics distributor. Authorized returns must be shipped prepaid. Repaired or replacement products will be shipped by Delta Electronics F.O.B. shipping point.
3. Delta Electronics shall not be liable for any indirect, incidental, consequential, punitive, or special damages arising out of or in connection with products use or performance, regardless of the form of action whether in contract, tort (including negligence), strict product liability or otherwise.
4. This warranty does not extend to fluorescent lamp starters and tubes.
5. The warranty does not cover if user does not comply with manufacturer's installation manual.
6. To qualify for warranty service, you must notify Delta Electronics at the address or telephone number below.
7. Delta Electronics shall have no liability to the original owner-user with respect to any defect caused by abuse, misuse, neglect, improper transportation or storage, improper testing, improper installation, improper operation, improper use, improper maintenance, improper repair, improper alteration, improper modification, tampering or accident of products or parts thereof, or unusual deterioration or degradation of products or parts thereof due to a physical environment beyond the requirement of products' specifications.