



(Fan/Dimmable LED Light/Night-Light – 80/110 CFM)

	<b>Full Speed:</b>	<b>Full Speed:</b>		
	80 CFM/<0.3 Sones @ 0.1" SP, 6.2 Watts 80 CFM/0.5 Sones @ 0.25" SP, 9.9 Watts	110 CFM/<0.3 Sones @ 0.1" SP, 8.2 Watts 110 CFM/0.6 Sones @ 0.25" SP, 14.1 Watts		

### Description

Low noise ceiling mount ventilating fan rated for continuous running. Fan has been awarded ENERGY STAR® Most Efficient 2023. It is HVI, UL, and cUL certified to comply with ASHRAE 62.2 local and whole building continuous and intermittent operation. Meets CA Title 24 requirements.

### DC Motor/Blower

- Power rating of 120 volts/60Hz
- Brushless DC motor engineered to run continuously
- Motor equipped with thermal cutoff fuse
- Removable with permanently lubricated plug-in motor
- Full speed adjustable, 80 or 110 CFM
- Built-in soft start function increases bearing life
- Automatically powers OFF if impeller is locked abnormally
- Self-compensating motor speed for intended airflow when static pressure is encountered

### Housing

- Galvanized steel body
- Detachable 6" diameter metal duct adapter
- Includes 6" to 4" duct reducer
- Built-in backdraft damper
- Easy installation with expandable extension bracket

### Grille

- Attractive design using ABS material
- Attaches directly to housing with torsion springs
- White

### LED Indicator

- Turn the power switch on/off to operate on/off  
LED indicator will be green when power is on

### Warranty

- 3-Year limited warranty

### TYPICAL SPECIFICATION

Ventilation fan shall be Delta Breez model SIG80-110; ENERGY STAR qualified with Brushless DC Motor engineered to run continuously for a minimum 70,000 hours; airflow rating of 110 CFM and loudness rating of <0.3 Sones at 0.1" static pressure as certified by the Home Ventilating Institute (HVI); power consumption of 8.2 Watts with efficiency rating of 15.3 CFM/Watt at 0.1" static pressure; fan will feature motor lock protection and self-compensating motor speed for intended airflow when static pressure is encountered. UL and cUL listed for tub/shower enclosure when used with GFCI-protected branch circuit wiring.

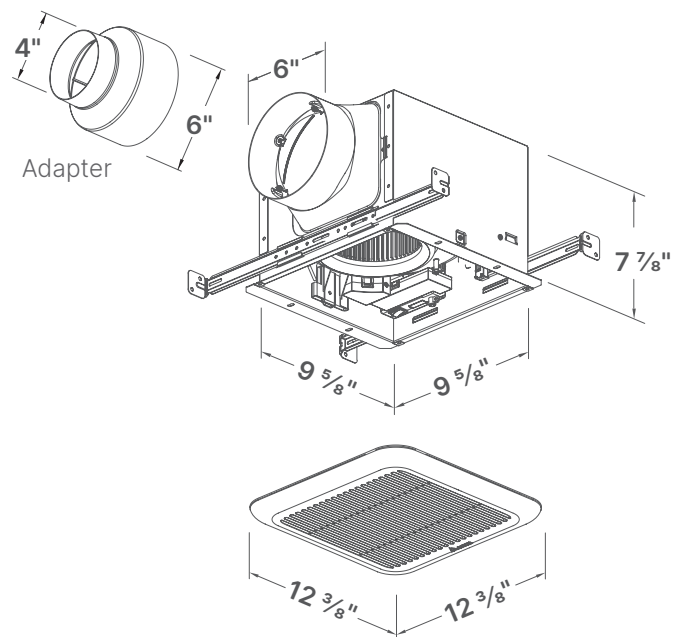

**SIG80-110 Fan Curve**

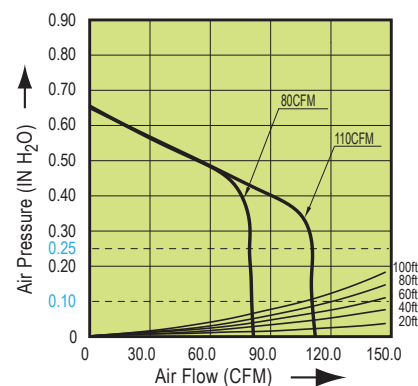



	<b>Full Speed:</b>	<b>Full Speed:</b>		
	80 CFM/<0.3 Sones @ 0.1" SP, 6.2 Watts	110 CFM/<0.3 Sones @ 0.1" SP, 8.2 Watts		
	80 CFM/0.5 Sones @ 0.25" SP, 9.9 Watts	110 CFM/0.6 Sones @ 0.25" SP, 14.1 Watts		

<b>BreezSignature SIG80-110</b>				
6" Duct Standard				
Fan Speed	Full Speed			
Static Pressure (Inches w.g.)	0.1	0.25	0.1	0.25
Air Flow (CFM)	80	80	110	110
Sones	<0.3	0.5	<0.3	0.8
Power Consumption (Watts)	6.2	9.9	8.2	14.1
Energy Efficiency (CFM/Watts)	15.4	9.0	15.3	8.7
Current (Amps)	0.38 Max			
Power Rating (V/Hz)	120 / 60			

<b>BreezSignature SIG80-110</b>				
4" Duct Standard				
Fan Speed	Full Speed			
Static Pressure (Inches w.g.)	0.1	0.25	0.1	0.25
Air Flow (CFM)	80	80	110	110
Sones	<0.3	1.2	1.0	2.0
Power Consumption (Watts)	7.4	11.8	12	17.5
Energy Efficiency (CFM/Watts)	12.5	7.9	10.5	6.9
Current (Amps)	0.38 Max			
Power Rating (V/Hz)	120 / 60			

Models	Quantity	Comments	Project:
			Location:
			Architect:
			Engineer:
			Contractor:
			Submitted by:
			Date: