

Description

Low noise ceiling mount ventilating fan with humidity sensor, rated for continuous running. ENERGY STAR® Most Efficient 2016. HVI, UL and cUL certified to comply with ASHRAE 62.2 local and whole building continuous and intermittent operation. Meets CA Title 24 requirements.

Motor/Blower

- Power rating of 110~220 volts/50~60Hz
- DC brushless motor engineered to run continuously
- Motor equipped with thermal cutoff fuse
- Permanently lubricated motor

Housing

- Galvanized steel body
- Detachable 4" diameter duct adapter
- Built-in backdraft damper.
- Easy installation

Grille

- Attractive design using ABS material
- Attaches directly to housing with torsion springs

Warranty

- 3-year limited warranty

Features

- Blue and amber LED indicator lights to show humidity sensor and full speed modes
- For ceiling mount only, airflow of 80 CFM (±10%) and <0.3 Sones at 0.1" static pressure
- Power consumption approximately 7.2 Watts with an efficiency rating approximately 11.0 CFM/Watt at 0.1" static pressure
- UL and cUL listed for tub/shower enclosure when used with GFCI branch circuit wiring

DC Motor Technology

- Allows fan to operate in full speed mode or humidity control mode by cycling the ON/OFF switch
- Built-in soft start function to increase bearings' life
- Automatically powers OFF when the impeller is locked abnormally

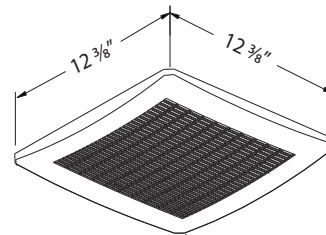
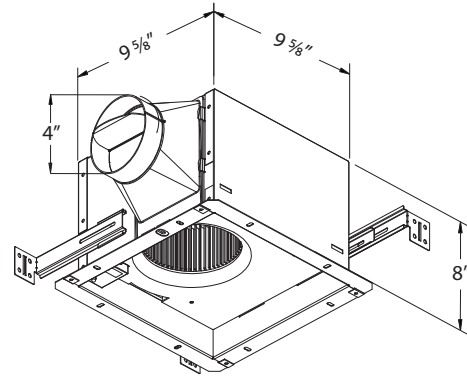

VFB080D4H1	4" Duct (Standard)	
Static Pressure (inches w.g.)	0.1	0.25
Air Flow (CFM)	80	56
Sones	<0.3	0.8
Power Consumption (Watts)	7.2	9.3
Energy Efficiency (CFM/Watt)	11.0	6.0
Current (Amps)	0.12 Max	
Power Rating (V/Hz)	110~220 / 50~60	

Fan Curve

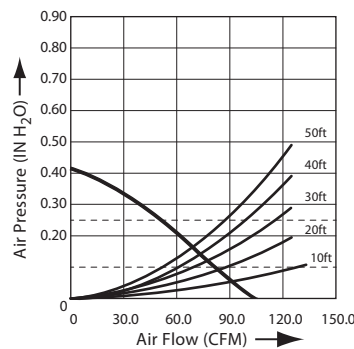

Humidity Control

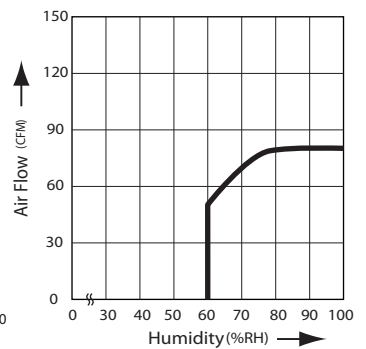

Model	Quantity	Comments	Project:
			Location:
			Architect:
			Engineer:
			Contractor:
			Submitted by:
			Date: