

Description

Low noise ceiling mount ventilating fan with humidity sensor, rated for continuous running. Fan has been awarded ENERGY STAR® qualified. Evaluated by Underwriter Laboratories and conforms to both UL and cUL safety standards.

Motor/Blower

- Power rating of 110~220volts/50~60Hz
- DC brushless motor engineered to run continuously
- Motor equipped with thermal cutoff fuse
- Permanently lubricated motor

Housing

- Galvanized steel body
- Detachable 4" diameter duct adapter
- Built-in backdraft damper
- Easy installation Galvanized steel body

Grille

- Attractive design using ABS material
- Attaches directly to housing with torsion springs

Warranty

- 3-year limited warranty

Features

- Blue and amber LED indicator lights to show humidity sensor and full speed modes
- For ceiling mount only, air flow of 130 CFM (±10%) and approximately 2.0 Sones at 0.1" static pressure
- Power consumption approximately 22 Watts with an efficiency rating approximately 6.7 CFM/Watt at 0.1" static pressure
- Duct diameter no less than 4"
- UL and cUL listed for tub/shower enclosure when used with GFCI branch circuit wiring

DC Motor Technology

- Allows fan to operate in full speed mode or humidity control mode by cycling ON/OFF switch
- Built-in soft start function to increase bearings' life
- Automatically powers OFF when impeller is locked abnormally

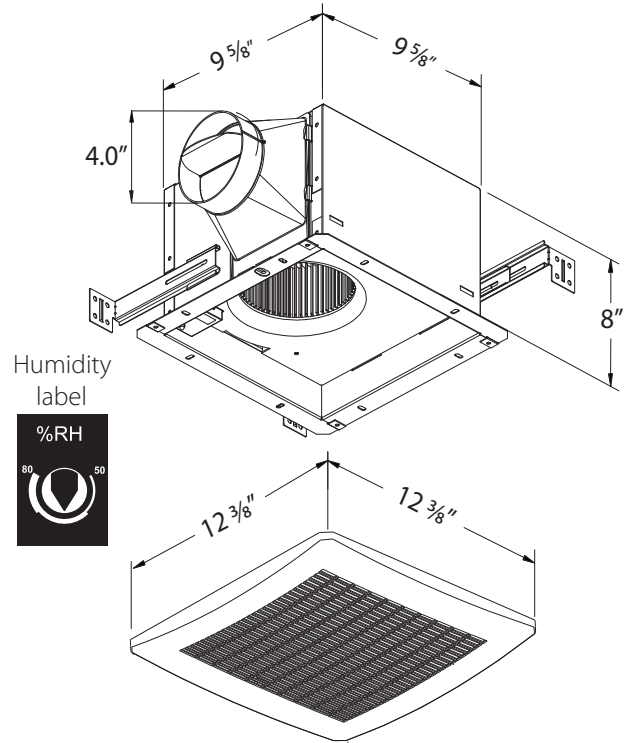

VFB25AEH	4" Duct (Standard)	
Static Pressure (inches w.g.)	0.1	0.25
Air Flow (CFM)	130	105
Sones	2.0	N/A
Power Consumption (Watts)	22	22
Energy Efficiency (CFM/Watt)	6.7	5.9
Current (Amps)	0.36 Max	
Power Rating (V/Hz)	110~220 / 50~60	

Fan Curve

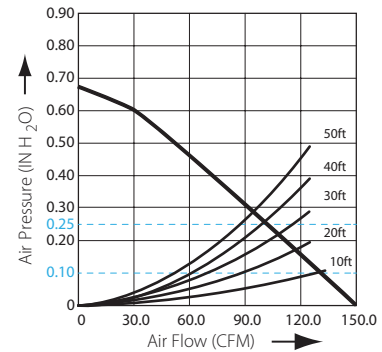

Model	Quantity	Comments	Project:
			Location:
			Architect:
			Engineer:
			Contractor:
			Submitted by:
			Date: