



(50 CFM)

	<p>3" Duct (Standard): 50 CFM/1.0 Sone @ 0.1 SP, 6.4 Watts 36 CFM/1.2 Sones @ 0.25 SP, 6.3 Watts</p>		
--	---	--	--

Description

Low noise ceiling/wall mount ventilating fan rated for continuous running. It is ENERGY STAR® Most Efficient in 2018. It is HVI, UL, and cUL certified, and can be used to comply with ASHRAE 62.2 (local and whole building continuous operation).

DC Motor/Blower

- Power rating of 120 volts/60Hz
- DC brushless motor engineered to run continuously
- Motor equipped with thermal cutoff fuse
- Removable with permanently lubricated plug-in motor
Built-in soft start function to increase bearings' life
- Automatically powers OFF when impeller is locked abnormally

Housing

- Galvanized steel body
- Detachable 3" diameter duct adapter
- Built-in backdraft damper
- Easy installation

Grille

- Attractive design using ABS material
- Attaches directly to housing with torsion springs

LED Indicator

- Turn the power switch on/off to operate on/off.
LED indicator will be green when power is on

Warranty

- 3-year limited warranty

TYPICAL SPECIFICATION

Ventilation fan shall be Delta Breez model SLM50; ENERGY STAR qualified with Brushless DC Motor engineered to run continuously for a minimum 70,000 hours; airflow rating of 50 CFM and loudness rating of 1.0 Sones at 0.1 static pressure as certified by the Home Ventilating Institute (HVI); power consumption of 6.4 Watts with efficiency rating of 11.6 CFM/Watt; fan will feature LED indicator running light and motor lock protection. UL and cUL listed for tub/shower enclosure when used with GFCI-protected branch circuit wiring

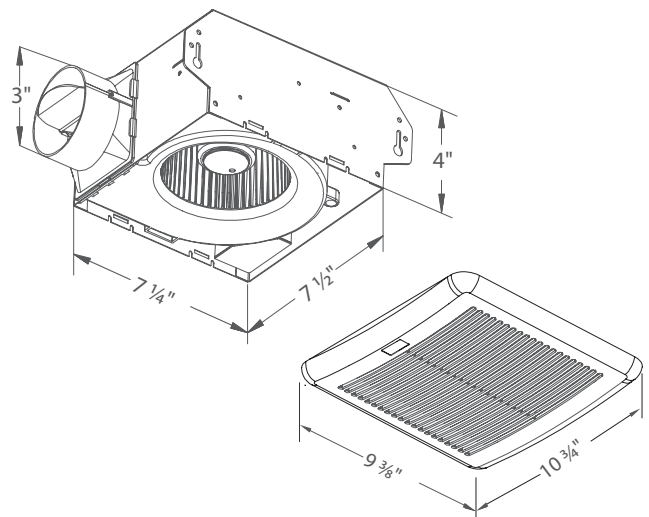

BreezSlim SLM50	3" Duct (Standard)	
Static Pressure (inches w.g.)	0.1	0.25
Air Flow (CFM)	50	36
Sones	1.0	1.2
Power Consumption (Watts)	6.4	6.3
Energy Efficiency (CFM/Watt)	11.6	7.4
Current (Amps)	0.18 Max	
Power Rating (V/Hz)	120 / 60	

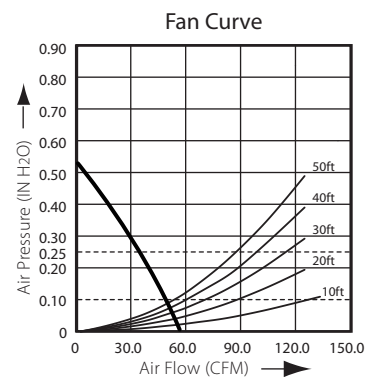

Model	Quantity	Comments	Project:
			Location:
			Architect:
			Engineer:
			Contractor:
			Submitted by:
			Date: