



4" Duct (Standard):
80 CFM/1.5 Sones @ 0.1 SP, 10.5 Watts
54 CFM @ 0.25 SP, 8.2 Watts



Description

Low noise ceiling mount ventilating fan, light, and heat. cUL listed and Home Ventilating institute (HVI) certified.

DC Motor/Blower

- Power rating of 120 volts/60Hz
- DC brushless motor engineered to run continuously
- Motor equipped with thermal cutoff fuse
- Removable with permanently lubricated plug-in motor
- Built-in soft start function to increase bearings' life
- Automatically powers OFF when impeller is locked abnormally

Housing

- Galvanized steel body
- Detachable 4" diameter duct adapter
- Built-in backdraft damper
- Easy installation

Grille

- Attractive design using PBT material
- 60W maximum lamp provides bright ceiling light (not included)

Heater

- 1300W heating element evaluated by cUL for safety standards
- Heater module equipped with thermal cutoff fuse and thermostat

Warranty

- 3-year limited warranty

TYPICAL SPECIFICATION

Ventilation fan shall be Delta Breez model RAD80L; brushless DC motor engineered to run continuously for a minimum 70,000 hours; airflow rating of 80 CFM (±10%) and 1.5 Sones at 0.1 static pressure. Power consumption approximately 10.5 Watts with an efficiency rating approximately 7.6 CFM/Watt. Duct diameter no less than 4" Built-in thermostat to regulate temperature. Metal guard to help prevent user contact with heating wire. Heater element with 1300W and conforms to UL safety standards. Heater module equipped with thermal cutoff fuse and thermostat.

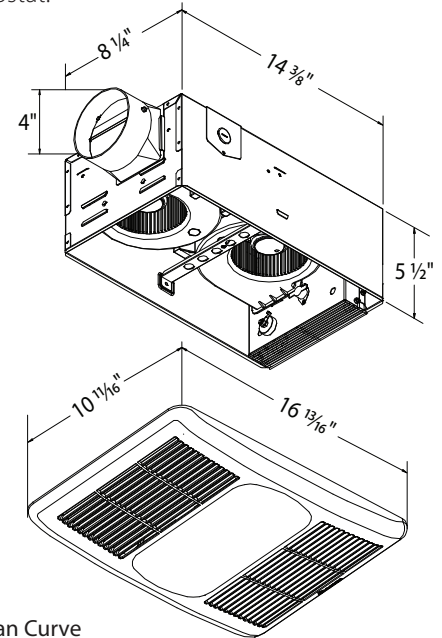

BreezRadiance RAD80L	4" Duct (Standard)	
Static Pressure (inches w.g.)	0.1	0.25
Air Flow (CFM)	80	54
Sones	1.5	N/A
Power Consumption (Watts)	10.5	8.2
Energy Efficiency (CFM/Watt)	7.0	6.4
Current (Amps)	12	
Power Rating (V/Hz)	120 / 60	
Heating element (Watts)	1300	
Total power (Watts)	1400	

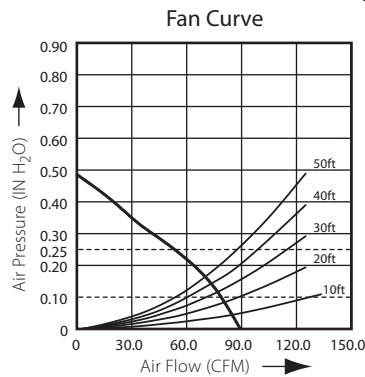

Model	Quantity	Comments	Project:
			Location:
			Architect:
			Engineer:
			Contractor:
			Submitted by:
			Date: