



MODEL: FRS200/VDBFRS200

(200/170/150/130/110/90/70/50/40/30 CFM)



6" Duct (Standard):
200 CFM@ 0.2 SP, 33.0 Watts



Description

High air flow and low noise fresh air supply fan allows you to select your required airflow [30-200 CFM]. Fan is ENERGY STAR® qualified, HVI, UL and cUL certified, and can be used to comply with ASHRAE 62.2.

Motor/Blower

- Power rating of 120 volts/60Hz
- Fresh air supply rates shall be manually adjustable for 30-40-50-70-90-110-130-150-170-200
- Constant airflow blower designed to maintain the selected air flow in standard installations
- ECM motor engineered to run continuously
- Motor equipped with thermal cutoff fuse
- Removable with permanently lubricated plug-in motor
- Built-in soft start function to increase bearings' life
- Automatically powers OFF when impeller is locked abnormally

Housing

- Galvanized steel body
- Detachable 6" diameter plastic duct adapter
- Built-in backdraft damper
- Easy installation with bracket
- Insulated housing to prevent condensation and noise

Features

- Pre-filter included; Optional MERV 13 filter
- Five installation possibilities: ceiling hung, under ceiling, wall mounted, attic mounted, flush to ceiling

TYPICAL SPECIFICATION

Ventilation fan shall be Delta Breez model FRS200; ENERGY STAR qualified with ECM motor engineered to run continuously for a minimum 70,000 hours; airflow rating of from 30 to 200 CFM as certified by the Home Ventilating Institute (HVI); at 0.2 static pressure. Power consumption of not more than 33.0 Watts with efficiency rating of not less than 6.0 CFM/Watt at 0.2" static pressure. Housing shall be insulated to reduce condensation and noise.



BreezFresh FRS200	6" Duct (Standard)
Length	15"
Width	10"
Height	10"
Ports diameter	6"
Operating temperature	14°F~104°F

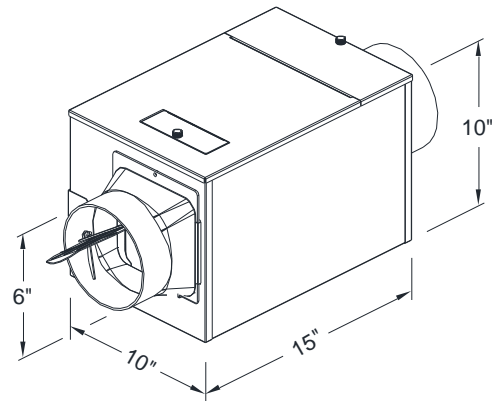

Specifications

Performance with pre-filter installed

Static pressure (inch w.g.)	0.2									
Air flow setting (CFM)	200	170	150	130	110	90	70	50	40	30
Power Consumption (Watts)	33.0	23.5	18.8	16.2	11.7	10.0	8.0	6.3	5.4	4.7
Static pressure (inch w.g.)	0.4									
Air flow setting (CFM)	197	170	150	129	110	90	70	47	40	30
Power Consumption (Watts)	42.0	34.9	29.0	22.5	19.5	15.9	13.0	10.5	9.2	8.5

Performance with pre-filter & MERV 13 filter installed

Static pressure (inch w.g.)	0.2									
Air flow setting (CFM)	200	170	150	130	110	90	70	50	40	30
Power Consumption (Watts)	42.0	29.3	22.7	19.1	14.1	11.4	8.5	7.2	6.1	5.2
Static pressure (inch w.g.)	0.4									
Air flow setting (CFM)	160	160	150	130	110	90	70	50	40	29
Power Consumption (Watts)	35.2	35.2	33.6	27.7	21.7	17.7	12.8	11.8	9.8	9.0

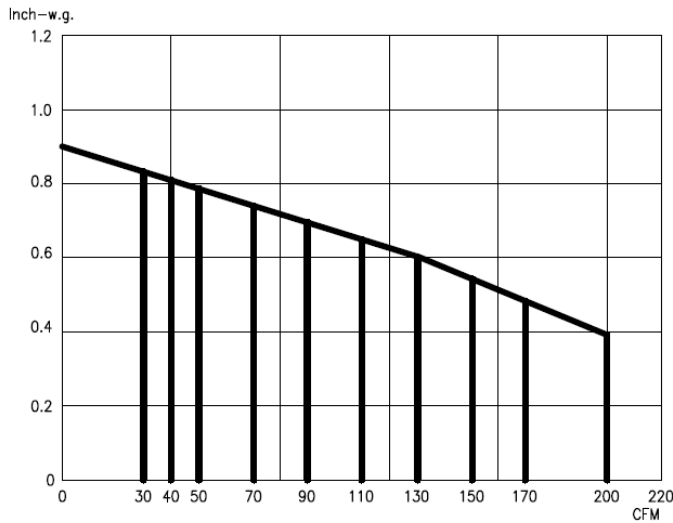

PQ Curve with pre-filter

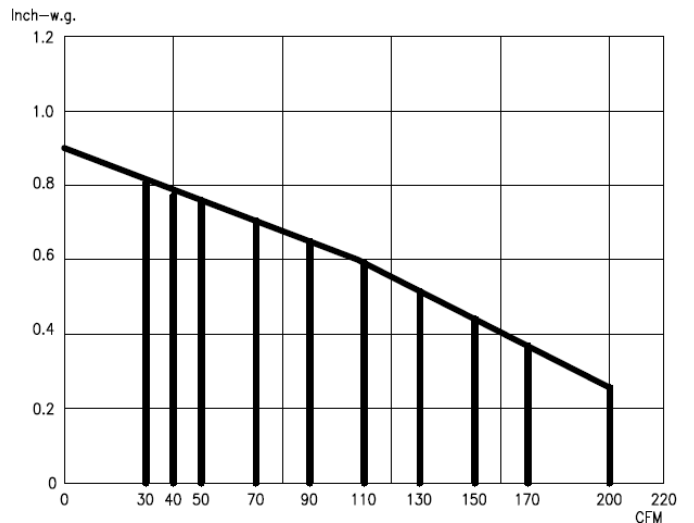

PQ Curve with pre-filter & MERV 13 filter

Model	Quantity	Comments	Project:
			Location:
			Architect:
			Engineer:
			Contractor:
			Submitted by:
			Date: